

Ellie T. Xu

- Electrical Engineering Portfolio -

Electrical Engineer at Level Home

May 2023 – end of August 2023

- Gathered requirements and developed a PCB (from block diagrams to the layout) that addressed a teamwide workflow issue.
- This device incorporated FTDI, Jlink, analog switches, adaptive power rail systems, etc.
- Worked with the mechanical and firmware teams to ensure functionalities. Completed bring-up with no issues found.
- **Positive feedback from teammates. Resulted in 50 fixtures being made and distributed company wide.**

Schematic of this board :

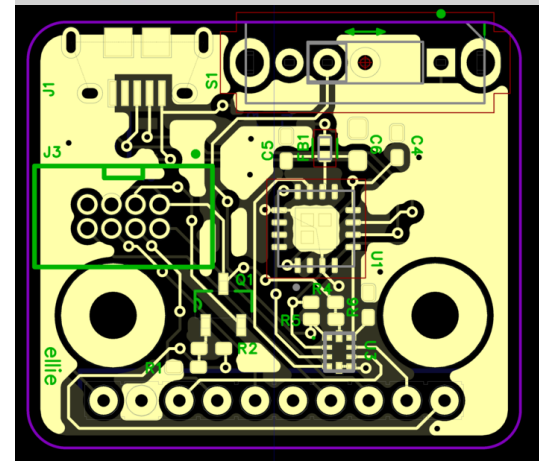
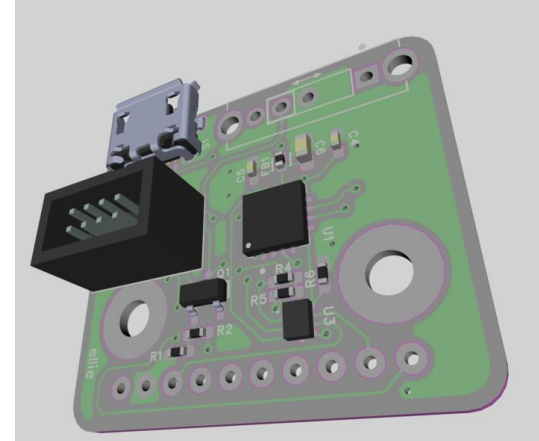
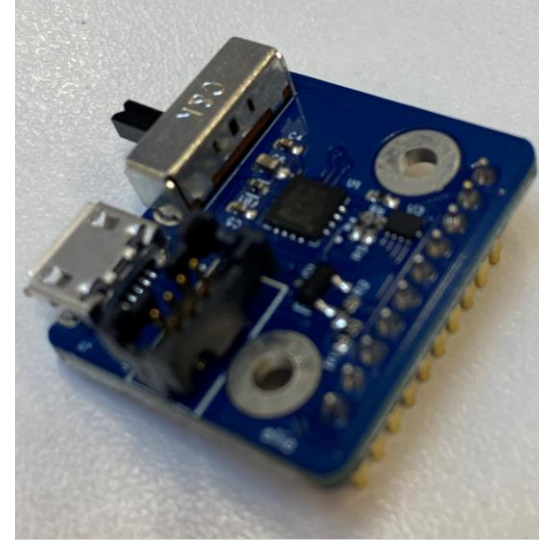
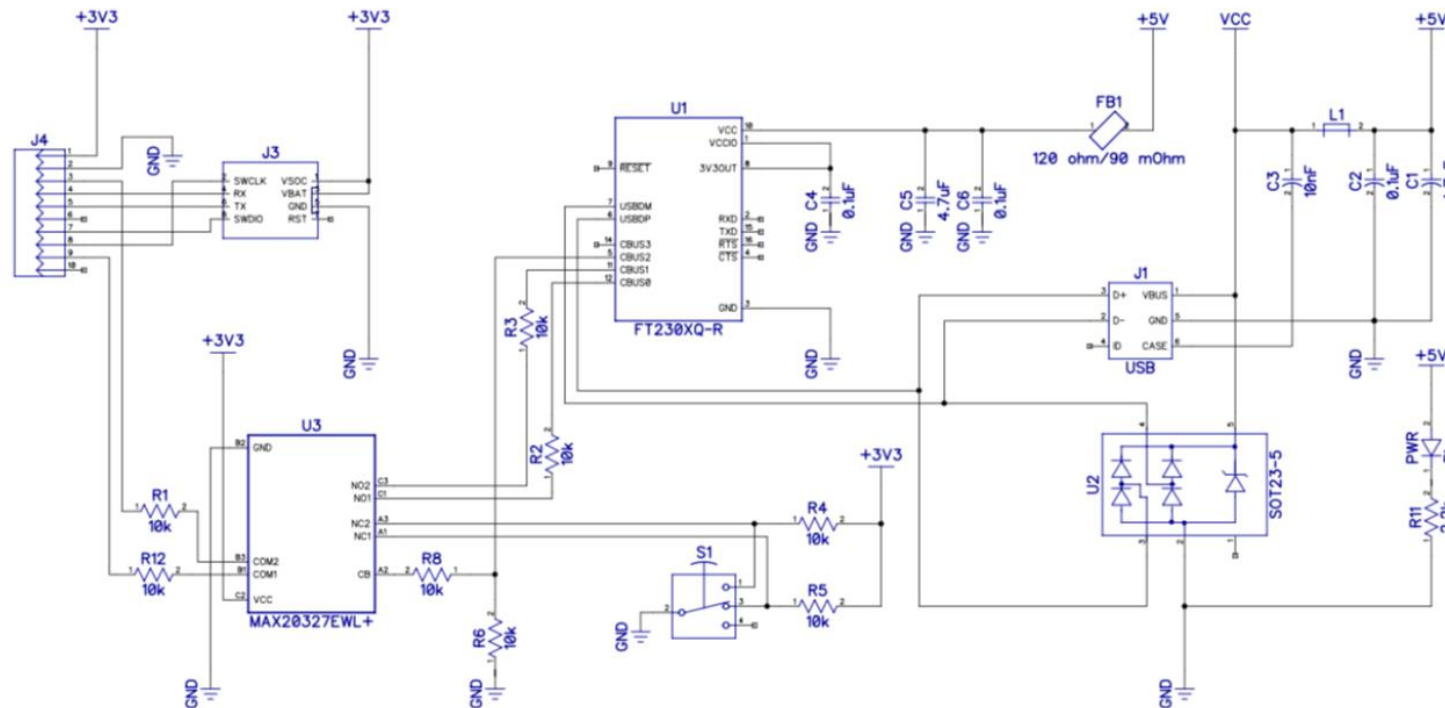

Electrical Engineer at Level Home

Cycle test fixture:

- **Led the electrical design of a cycle test fixture that successfully tested multiple products over thousands of cycles.**
- This achieved motor control and position sensing by using Hall effect sensors, H-bridge drivers, regulators, Raspberry pi etc.
- Followed through by also writing python scripts for autonomous cycle fixture testing.
- Collaborated with the ME team to obtain needs and requirements.

R&D Topics:

- Prototyped R&D projects and demonstrated their functionalities to the team. This includes **e-paper, capacitive touch, haptic touch, led boards, UWB, Bluetooth**, etc.
- Completed board bring ups. Resolved issues from wrong trace wirings to slow SWD rise times.
- Completed Python and Arduino scripts to demonstrate functionalities of projects and to automate processes. Practiced OOP architecture for maintainability and expandability for the future.
- Soldered components as small as 0402 packages under the microscope.

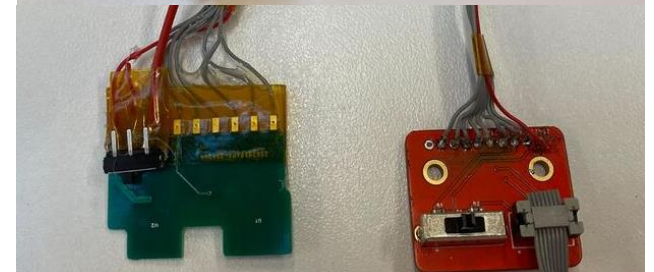
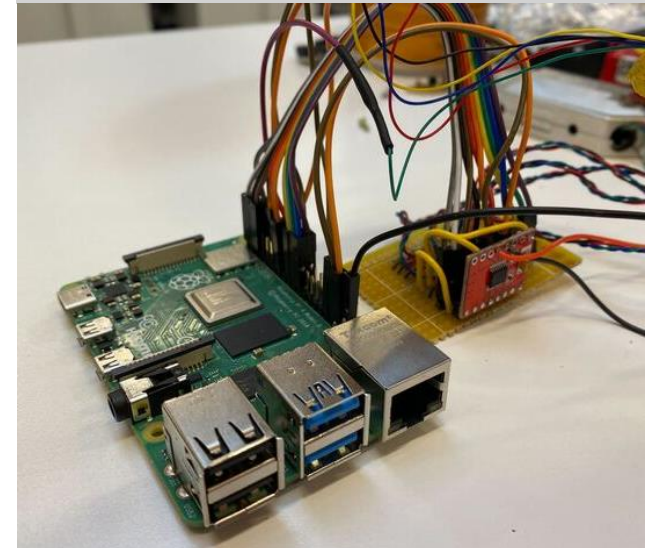
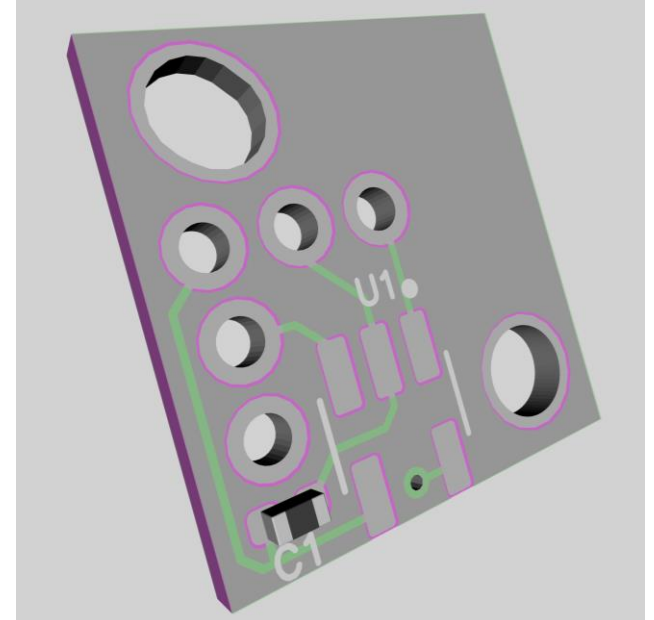

Electrical Engineer at Nuvation Garage

Remote emergency stop receiver schematic

- Collaborated with team to create a remote E-stop for the Burning Man platform project.
- Created the receiver schematic by using JTAG, RF module, and an MSP microcontroller for future expandability.

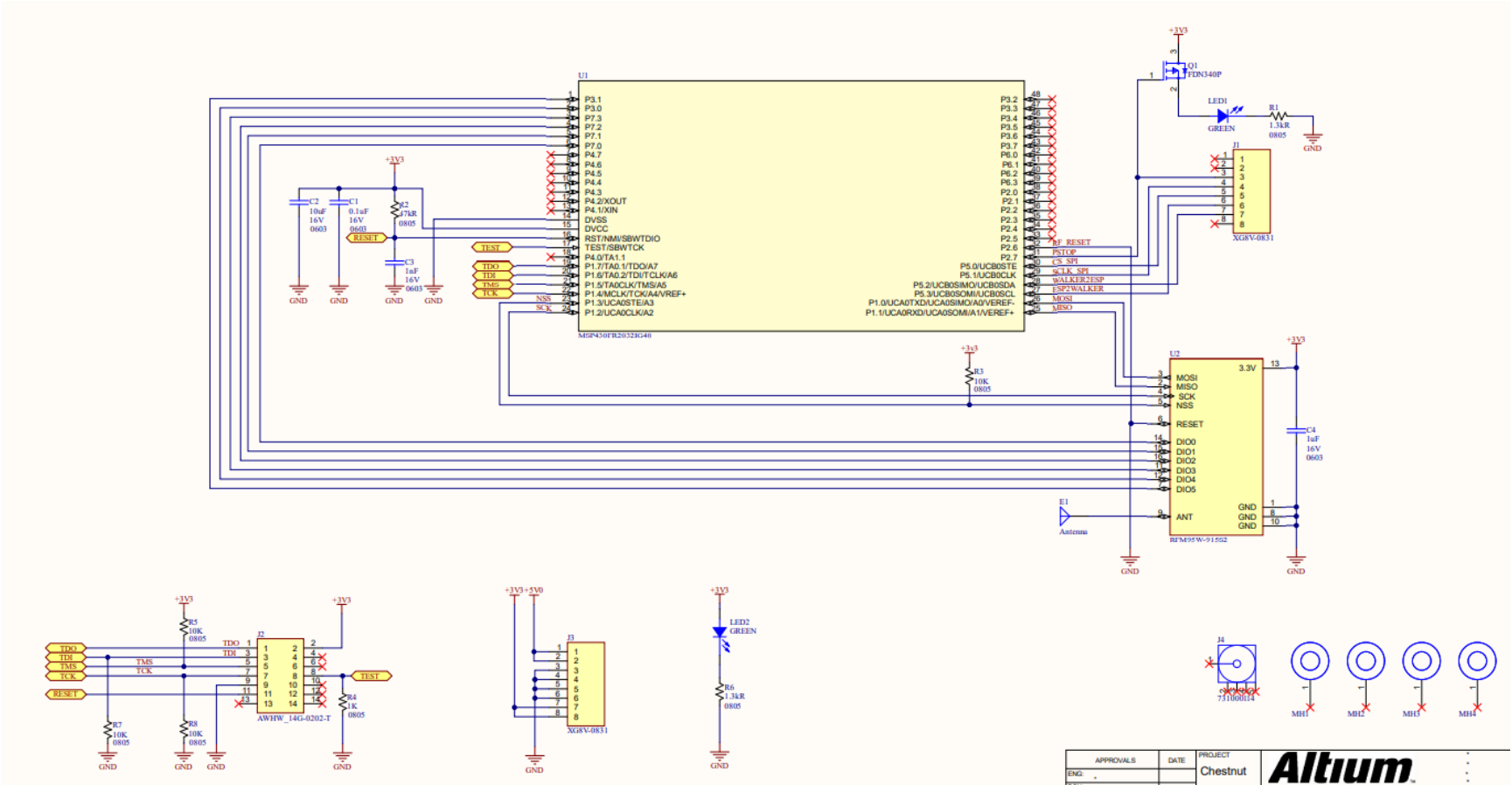

CODIA

- Built a modulated robot from ideas to testing with an alterable configuration designed to adapt to perform various tasks.
- **Received national recognition at a Canada-wide event with a bronze medal.**
- Researched and developed a low-cost user interface through wireless hand gestures. Designed to act as an artificial assistant.

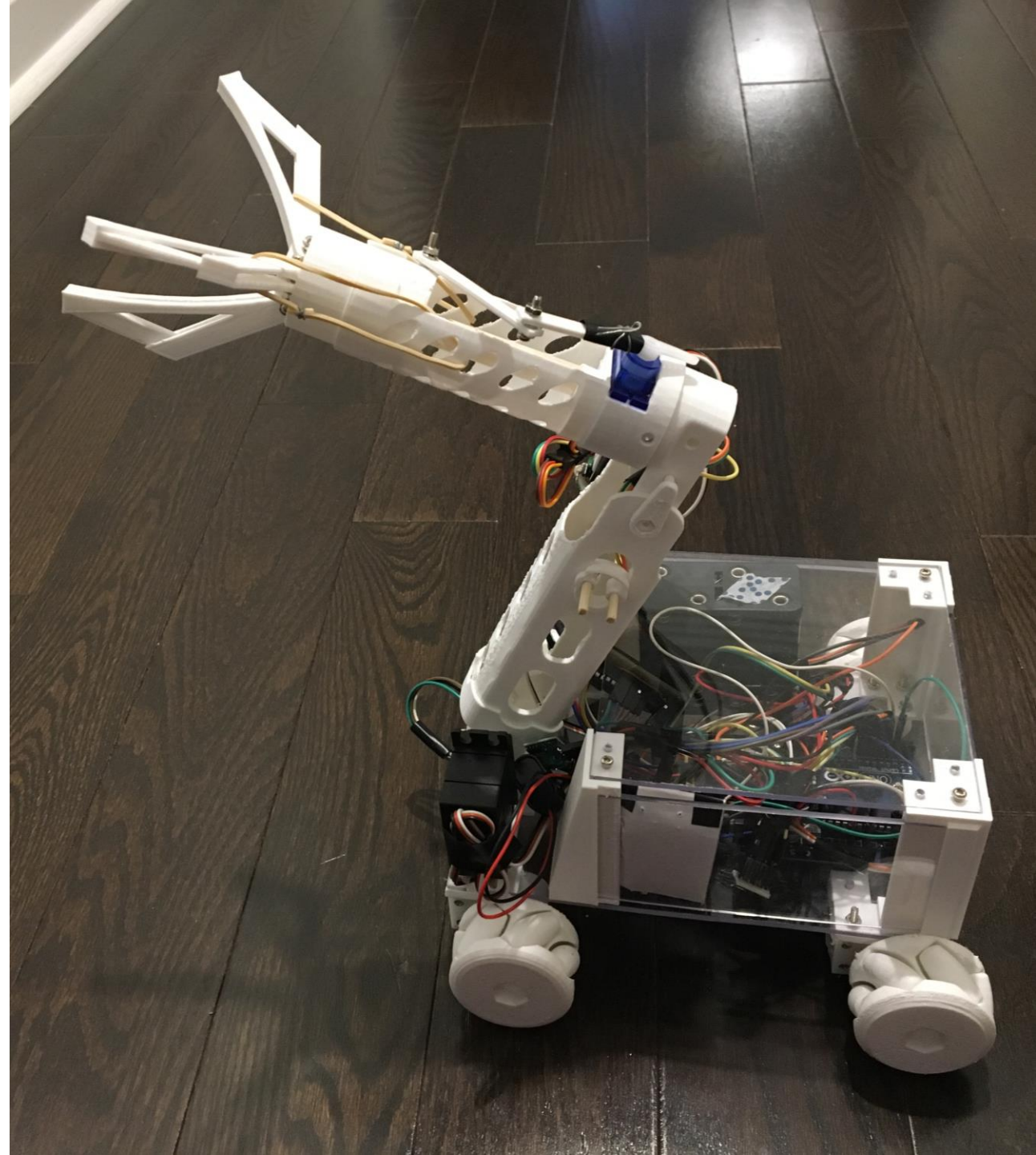

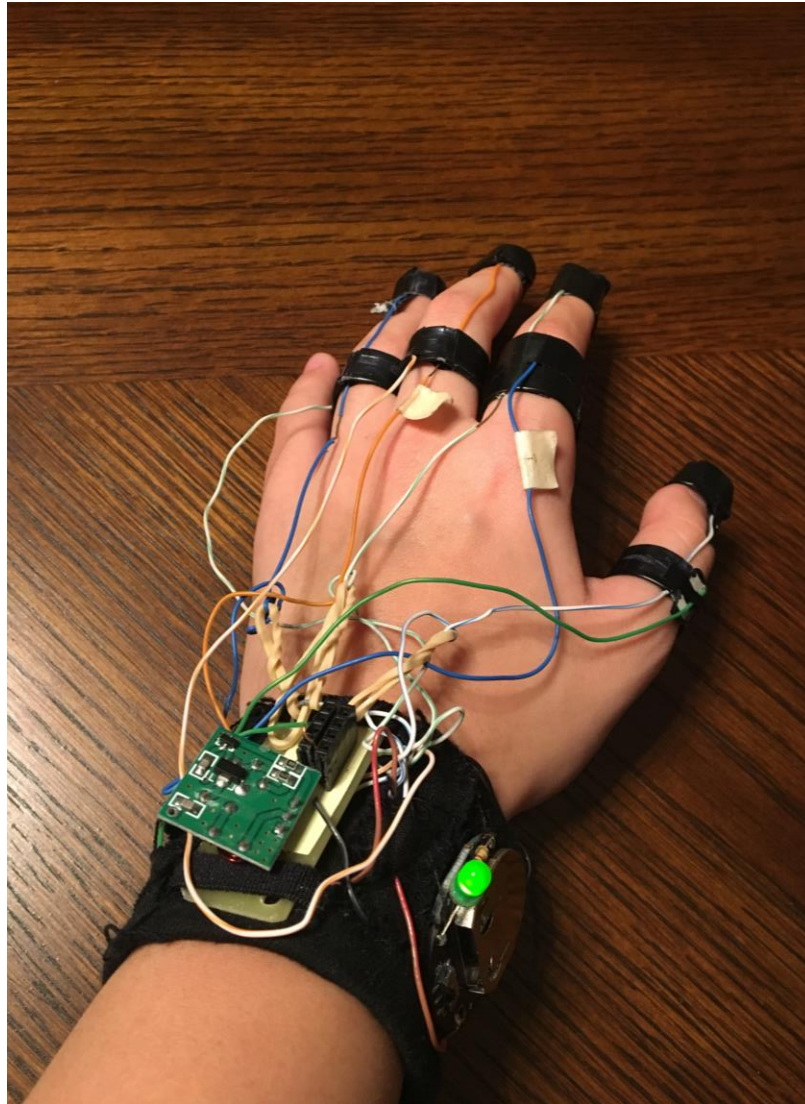

CODIA

(continued)

- Completed several prototyping stages from wood to 3D printed parts.
- Designed so that it has automatic configuration recognition through hardware IDs.
- Wrote all software including controls. This ensured the behaviours matched the hardware configurations.

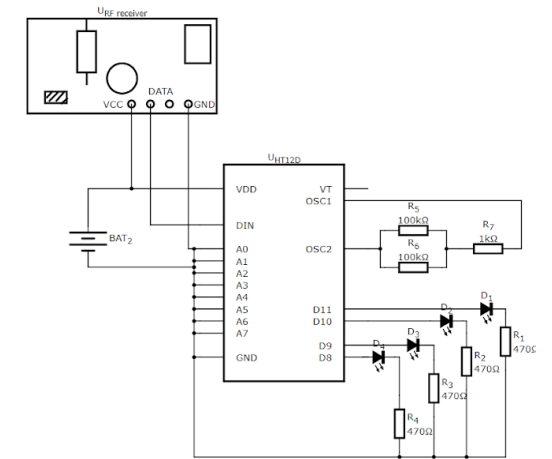

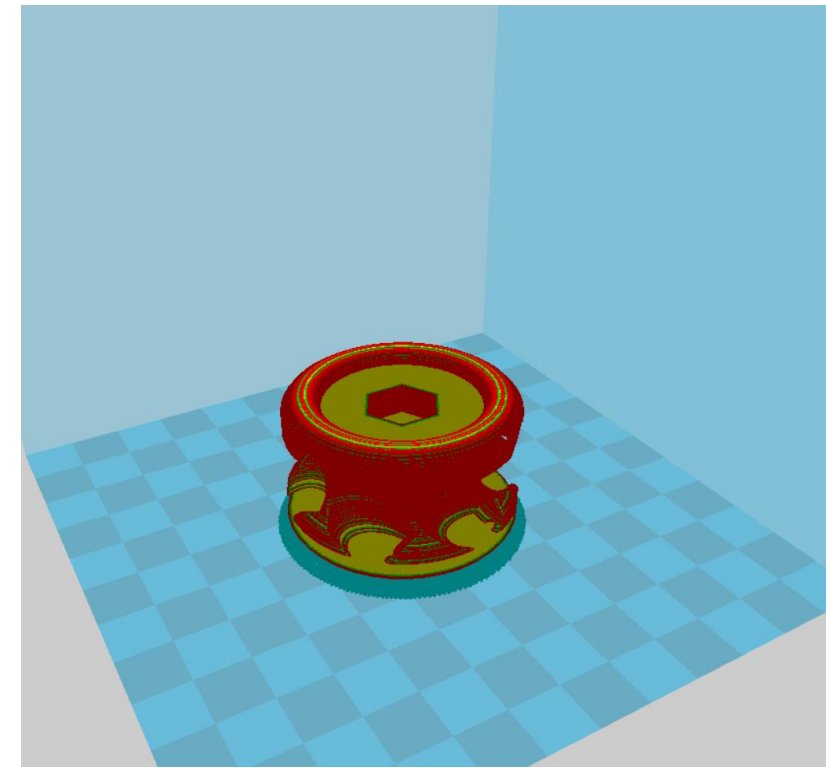
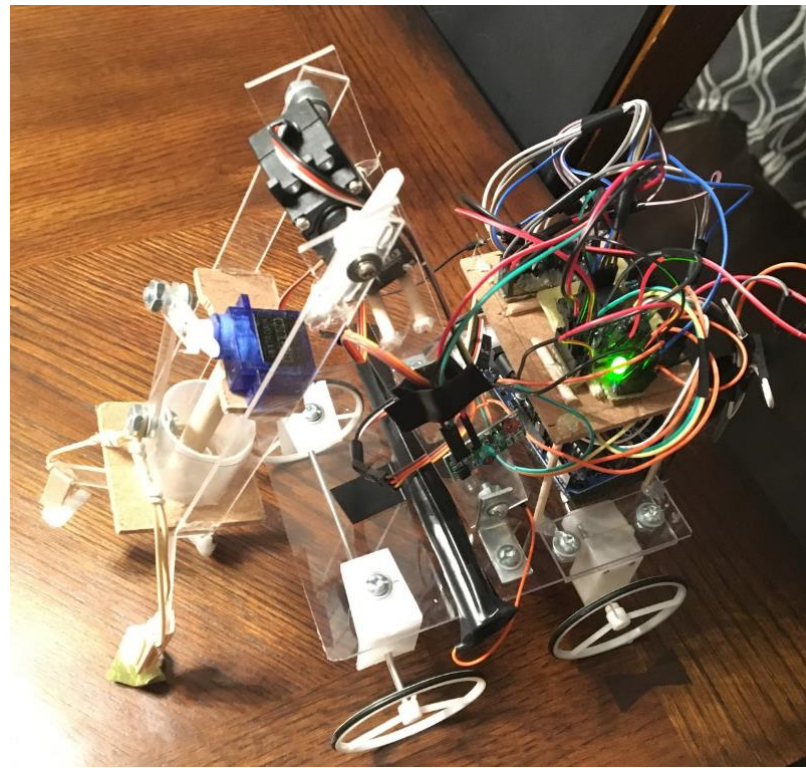
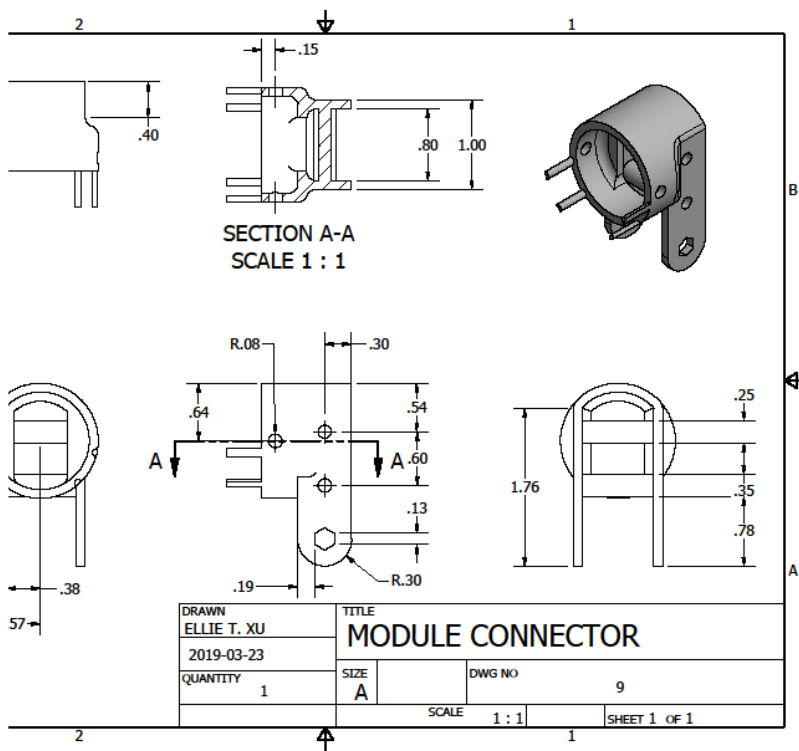

Mechanical Design

Autodesk Inventor

- Researched and 3D modelled all mechanisms such as the **chassis**, **electro-mechanical interfaces**, and **mecanum wheels** on Inventor.
- Developed drawings to help the manufacturing process. [Link for more drawings](#)

Prototype

Shop Tools

- Prototyped designs with wood and acrylic models before 3D printing the final.

3D Printing

3D Printing.

- **3D printed** complex parts with PLA plastic to increase structural integrity, precision, and functionality.

Thermoelectric 3-in-1

- **Created a temperature regulating container that was awarded a Gold medal in the Bay area science fair.**
- Functioned using the Peltier-Seebeck effect. It could act as a generator by using a temperature difference between the container contents and the environment or heat/cool down container contents using a power source.
- Adapted an H-bridge to allow current flow in both directions while being controllable over an MCU.
- Remote control over Wifi using an ESP module.

Modified H-bridge Design

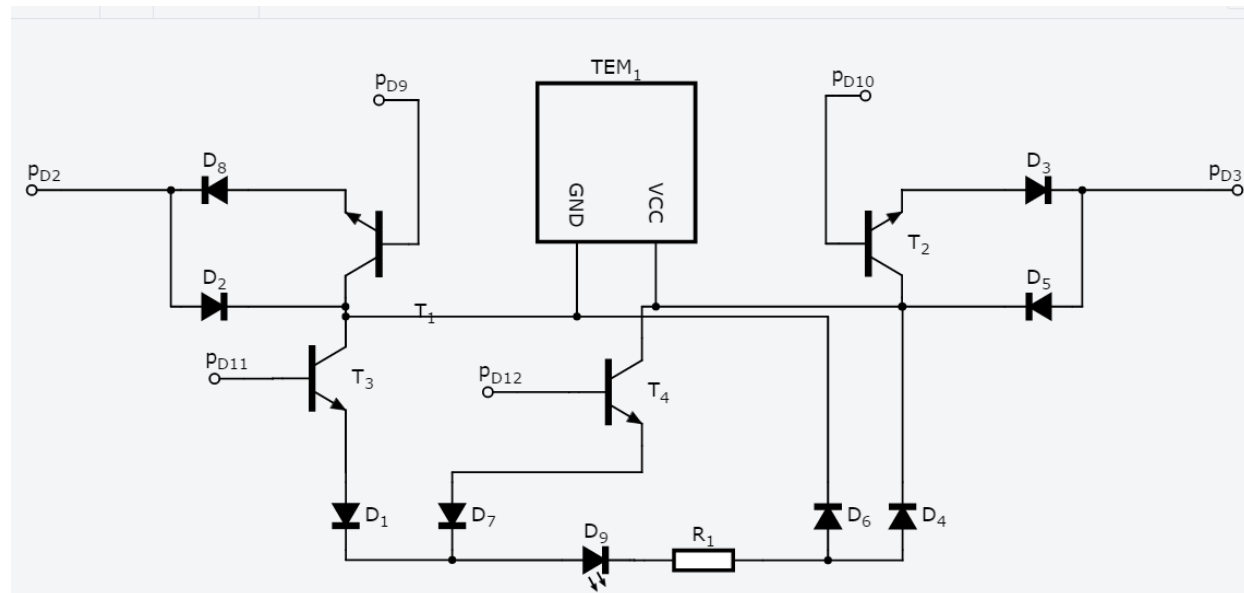

Hardware Engineer at UW Orbital Team

- Researched circuit protection systems for the cube sat team.
- Added load switches and MOSFETs to the battery management system.
- Explored many different solutions that included multi-rail ICs, single-rail ICs, MOSFETS, and combinations to minimize cost and maximize application.

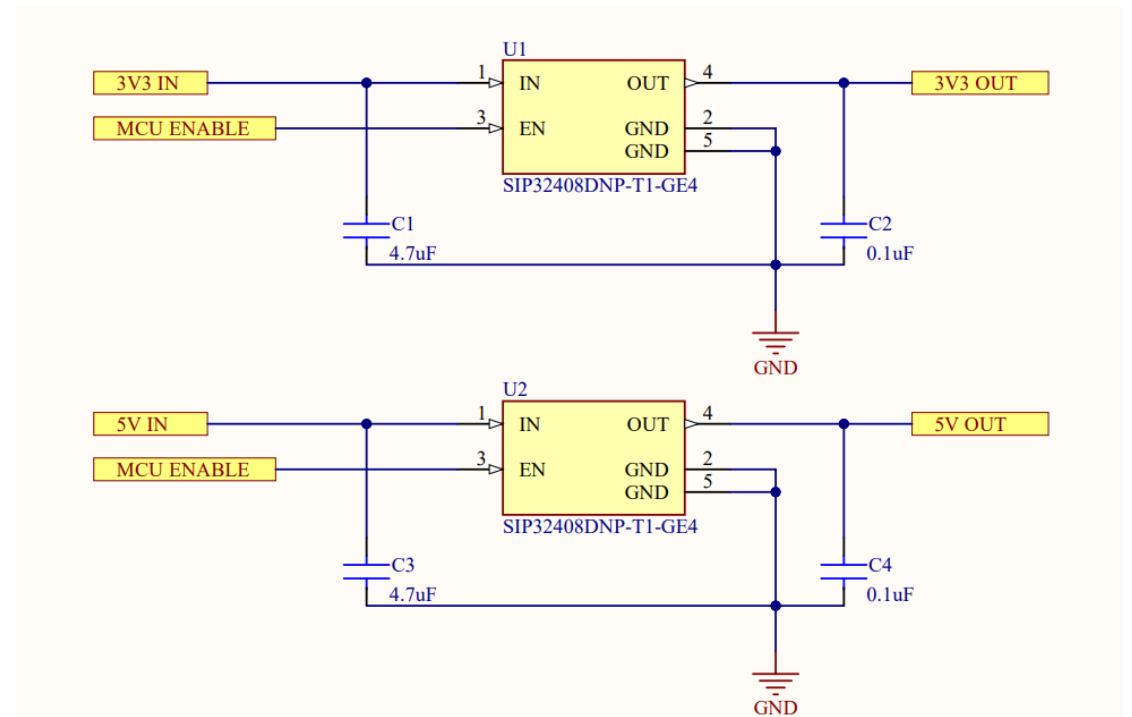
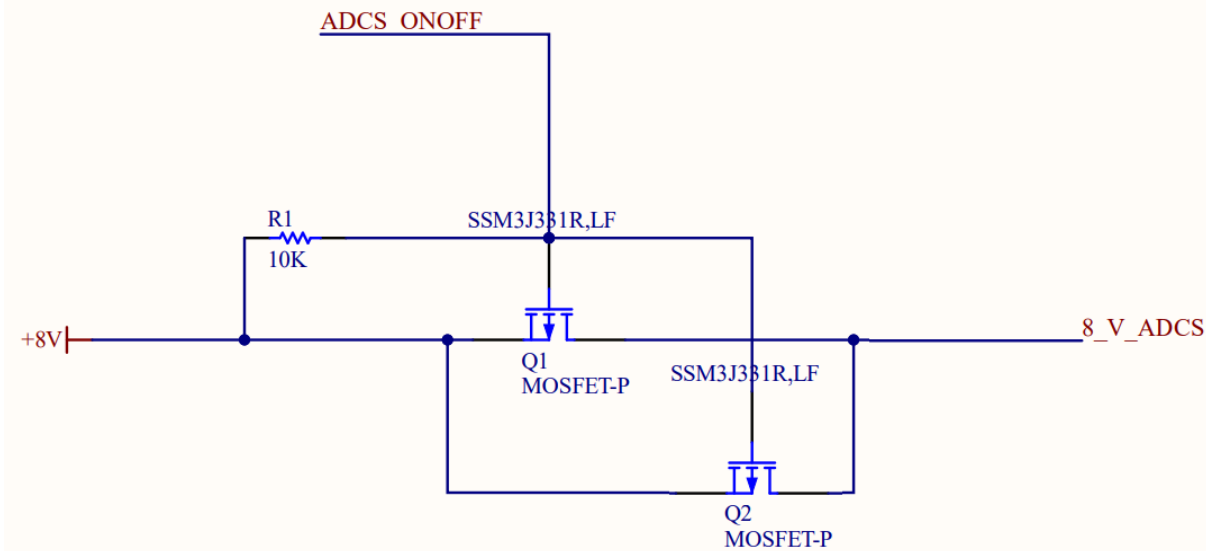

IoT Engineer at LimeTAC

Highlight project: real-time indoor vehicle tracking system

- Developed and deployed in warehouses a system that could track in real-time the location and movements of indoor vehicles (i.e. forklifts in a factory).
- Spearheaded all calculations, geometry, and camera integrations.
- Designed and created the **Python back-end** code and the **Tkinter GUI** shown on the image to the right.
- Conducted research and real time tests for both hardware and software in a warehouse.

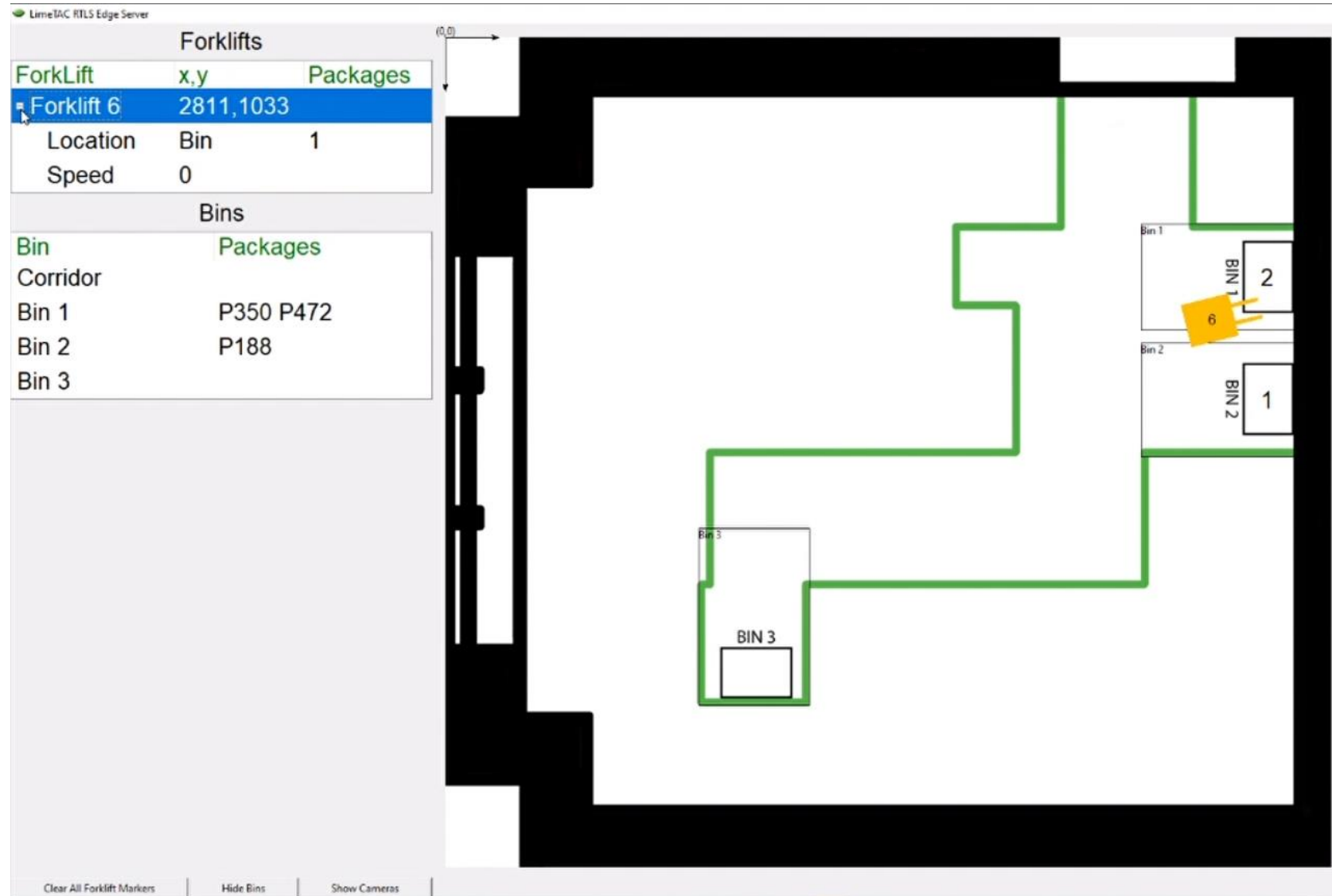

Real-time indoor vehicle tracking system GUI

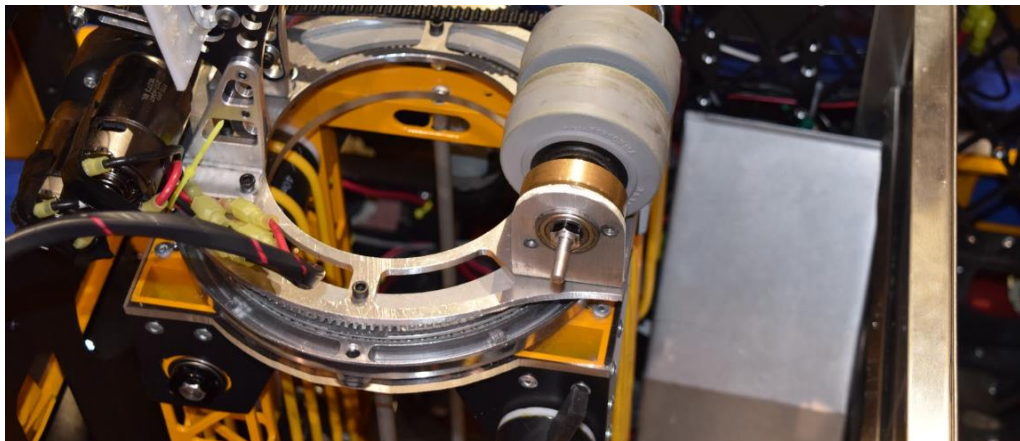
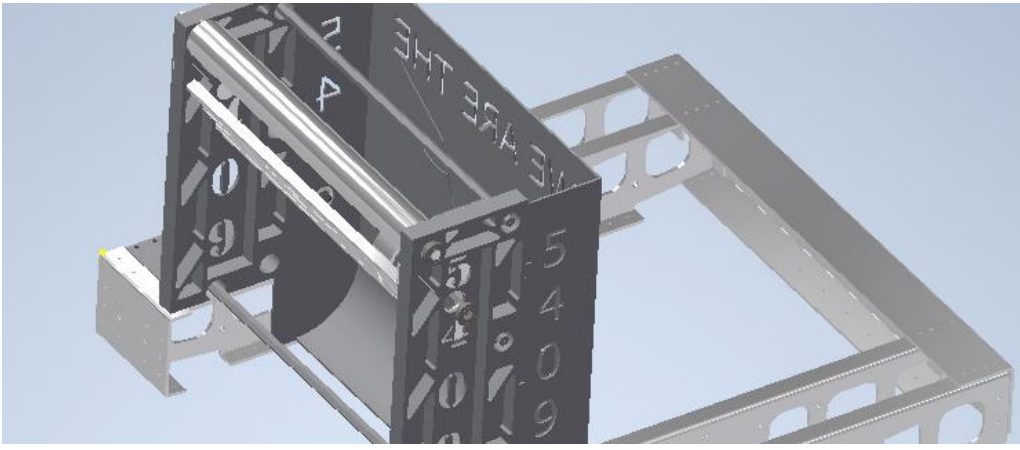
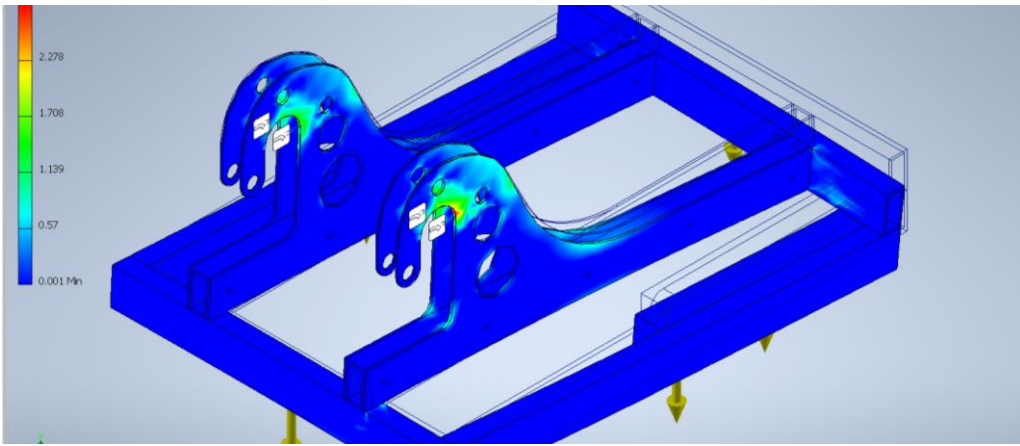

Core Mechanical Designer

FIRST Robotics team

- Produced 2D, 3D, and sheet metal models on **AutoCAD & Inventor** along with drawings that applied GD&T principles.
- Performed virtual **stress simulations** on models before production using Inventor.
- Research and prototyped solutions before officializing the final design.
- Manufactured prototypes and mechanisms with the plasma cutter, CNC, lathe, and other tools.



Core Mechanical Designer

FIRST Robotics



Power Up - 2018

Mechanism of focus: scissor Lift. Prototyping and 3D modelling the parts. Then weight reduction and stress simulations.

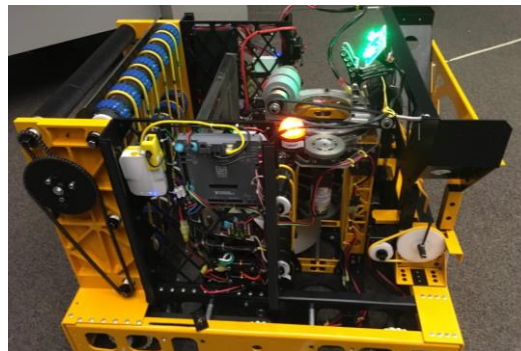

Steamworks - 2017

Mechanism of focus: climbing/intake mechanism. The physical integration of this system into the robot.

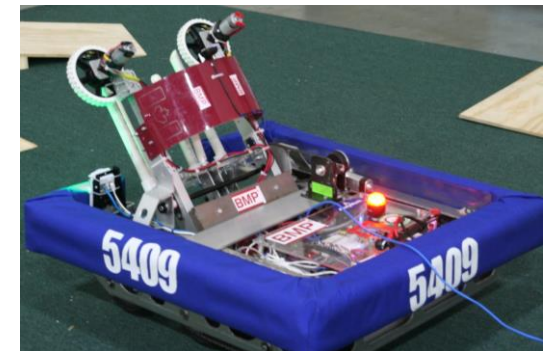

Stronghold - 2016

Mechanism of focus: mechanical grappling hooks. Led the research and prototype of several solutions from strong springs to tension cords.



Evaluations & Recommendations

"Ellie demonstrated exceptional creative problem-solving skills that surprised and impressed me on multiple occasions. When presented with a task, she was always able to quickly come up with a variety of solutions. She displayed this ability throughout the term on the various projects she worked on. Ellie had also demonstrated excellent persistence throughout the term. This was reflected on multiple occasions; she impressed me when she decided that unexpected issues did not mean the end of the project, even if those issues were large enough to halt it. Overall, Ellie showed an excellent ability to creatively solve any problems she was faced with and carried with her the persistence to follow through with a task despite the obstacles."

– LimeTAC CTO's comments

"Ellie Xu had exceeded significantly on all expectations. She delivered a high-quality work in a short time. She went above and beyond with all assignments. Always performed exceptionally and had significantly contributed to the organization through her works. She was able to solve complex code independently in a short period of time and even improved to a more efficient algorithms. This was reflected when she was given tasks to convert codes in VB to Python to format hundreds of Excel reports to a format we defined. She was also helping resolving defects on Python script to modify reports in Excel format to comply with AODA guidelines. She was able to perform the tasks without any helps considering the complexity of the codes. Previous students I worked with demonstrated the struggles in understanding and completing the task but Ellie managed to resolve issues we could not in the past."

– Ontario Ministry of Health Supervisor's comments



Some Additional Projects

EatOut

- Web scraped restaurant menus using Selenium and wrote the backend code (Google Cloud API, Python, and frontend communication using Flash). Then displayed nearby restaurants that matched customer's preferences.

AR Navigation

- An AR navigation app (made in Unity) that recognizes key features to determine locations.
- Projects 3D navigation directions on the glasses.

Web ID

- A series of dispensers that are connected to users' individual virtual wallets.
- Users are able to use virtual credits to purchase items.

EAT
OUT

CrowdMotions

- Wrote algorithms in Java & C# that learned sentiment values from preexisting data and used them to analyze new data.

Some Additional Projects

Netflix-N-Chill

- Developed the Chrome extension for the project with Javascript, HTML, and CSS. Then interfaced it with the backend through Firestore.
- Wrote python backend.

Edit Booking

Search by name

First name: Last name:

Search by date of birth

Month Day Year

Search by time of appointment (example: 07082018 14:30)

day month year: : : time of the day :

First name: Last name:

Phone number

Software developer at Halton clinic

- Proposed and programmed a patient booking software on Java as an alternative to paper bookings at my co-op placement.

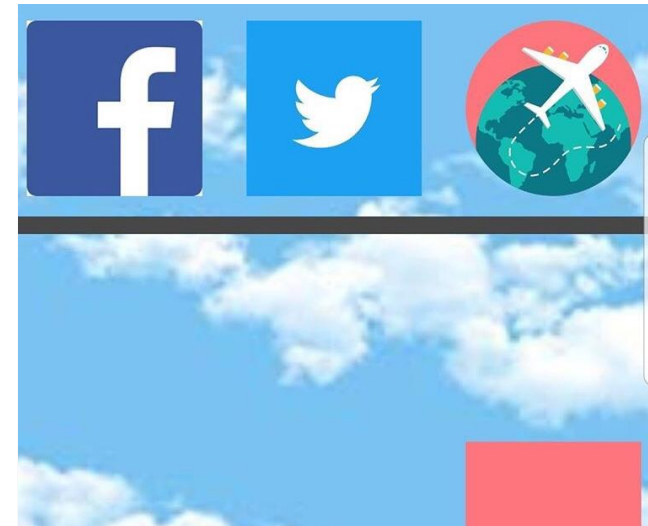

Software Developer at UWAF T team

- Developed a dashboard to display sensor data using Python (Tkinter and ROSpy) in OOP.

Some Additional Projects

Mechanical Engineer at Watlock

- Researched, modelled, and contributed to the airlock hatch door made to withstand Mars conditions on SolidWorks.

Mini Games

- Created Android Apps (Unity & C#) from Tic Tac Toe to custom arcade games.
- Created the classic 2048 game in Java.

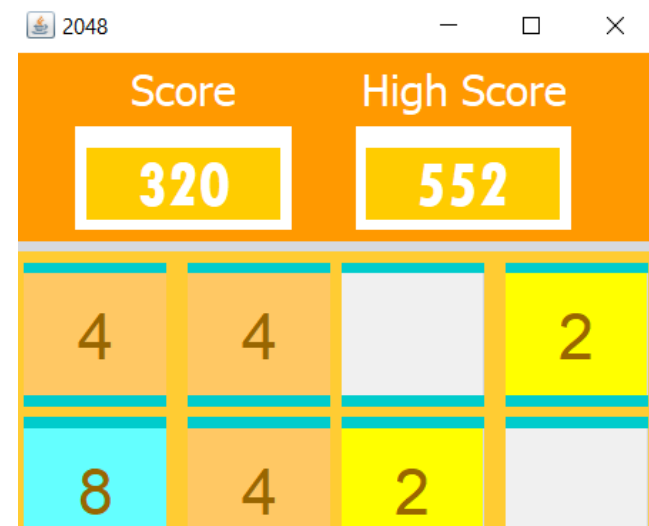
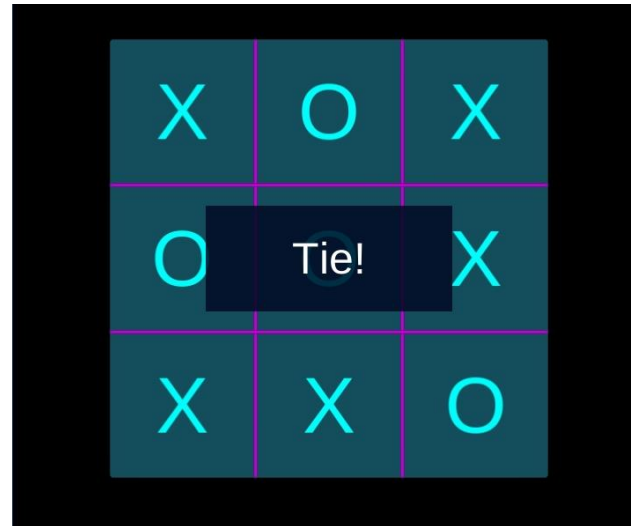

Ongoing projects

Pipe burst rescue system for homes Engineering 4th year capstone

- Developing and testing all electrical systems including power system, PCB layouts, and MCU selection.
- Prototyping an ultrasonic flow meter using TDC1000 and TDC7200 for nonintrusive pipe monitoring.

Research Assistant for Dr. Boumaiza at the University of Waterloo

- Research topic: wireless communication via unmanned aerial vehicles.
- Focusing on finding solutions for GPS disciplined oscillators.